

For detailed information on assembling the S16 visit:

<https://www.harvst.co.uk/support>

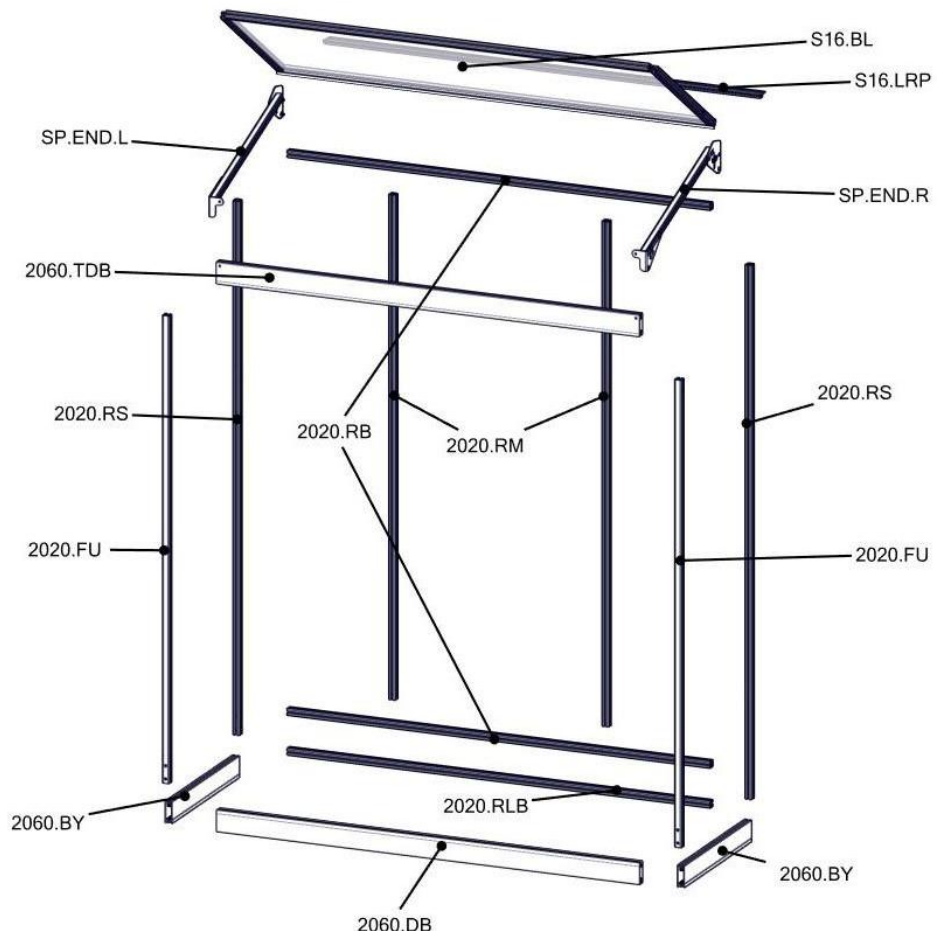





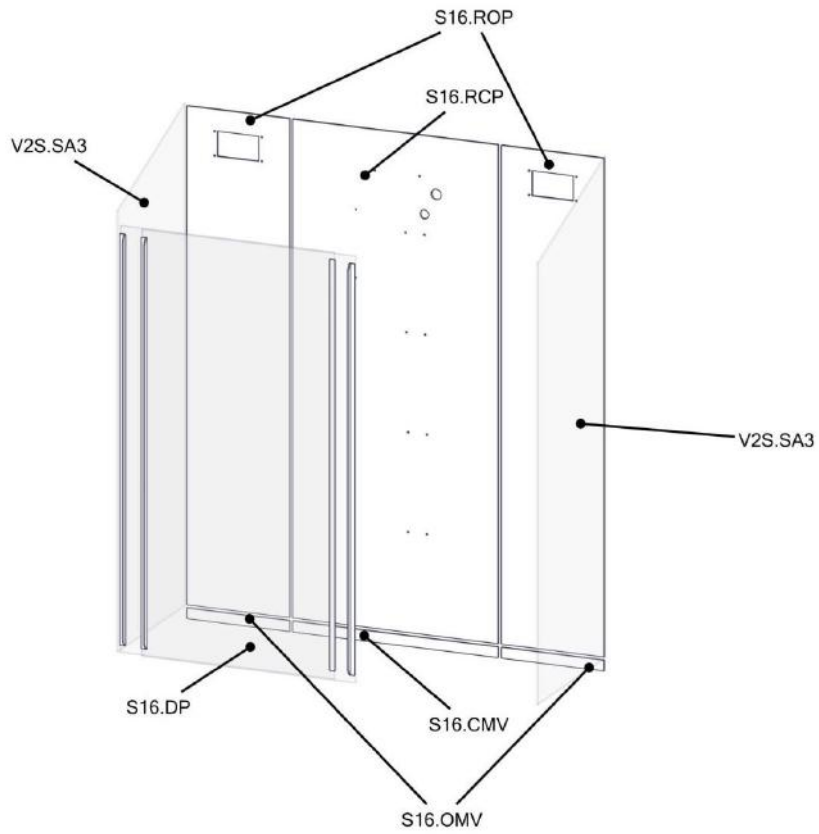





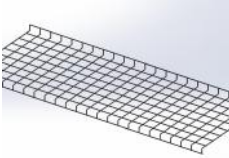
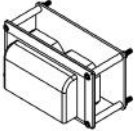

S16 frame parts

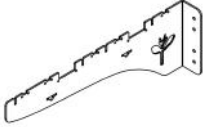

S16 panels

Components

Image	Name	Image	Name
	1x V2S.SCP <i>Control unit</i>		HOSE.2.5M <i>2.5m braided hose</i>
	1x PSU.200W <i>Power supply</i>		3x S16.ZM <i>Shelf mesh</i>
	2x 16.EXK <i>Twin fan</i>		3x V2S.SSB.R <i>Shelf support (R)</i>
	1x SENSOR.TEMP <i>Temperature sensor</i>		3x V2S.SSB.L <i>Shelf support (L)</i>
	1x V2S.HCS <i>Short cable</i>		1x V2S.IRR <i>Irrigation pack</i>
	2x V2S.HCL <i>Long cable</i>		1x V2S.W2SPLIT <i>Cable splitter</i>
	12x LED.FLAT.BAR		1 x 4MM.HOSE <i>4mm irrigation hose</i>

Fixings pack

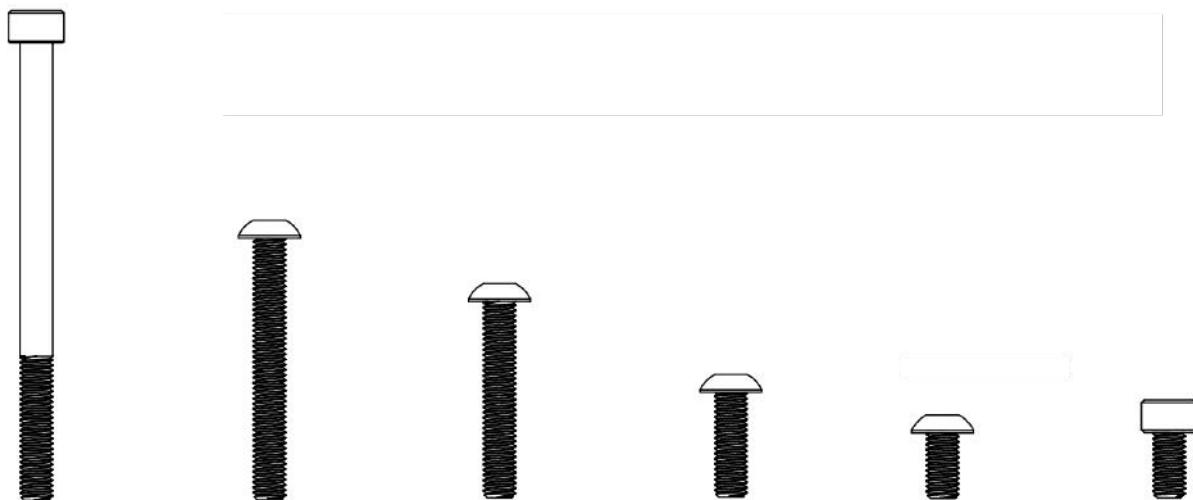

10x M5X70.C	2x M5X40.B	4x M5X30.B	16x M5X16.B	16x M5X8.B	24x M5X8.C
-----------------------	----------------------	----------------------	-----------------------	----------------------	----------------------

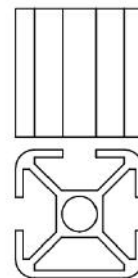
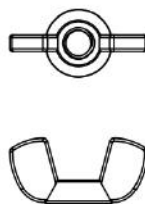

6x 10GX25.PAN Screw	40x M5.CN Channel nut	8x M5.N M5 nut	6x M5.WN Wing nut	12x M5.NY.N Nyloc nut	2x 20MM.SP Spacer
-------------------------------	---------------------------------	--------------------------	-----------------------------	---------------------------------	-----------------------------



2x M5.RW
Plastic spacer



16x M5.PW
Steel washer

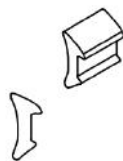

6.5m V2S.GST
Rubber trim

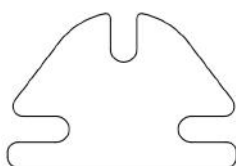

2x ATP
Anti twist plate

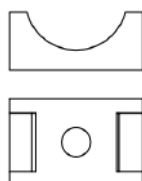

8x CTB
Cable tie base

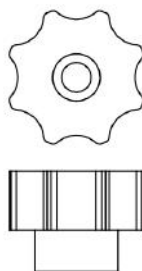

2x M5.PHN
Plastic handle nut

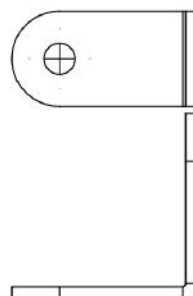

4x SAB.3030
Steel angle bracket



8x 50MM.SO
Plastic stand-off

Other small parts

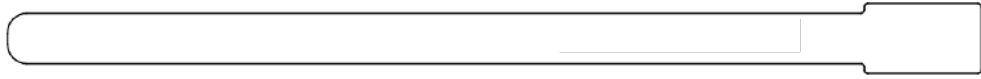

8x RCT Reusable cable tie

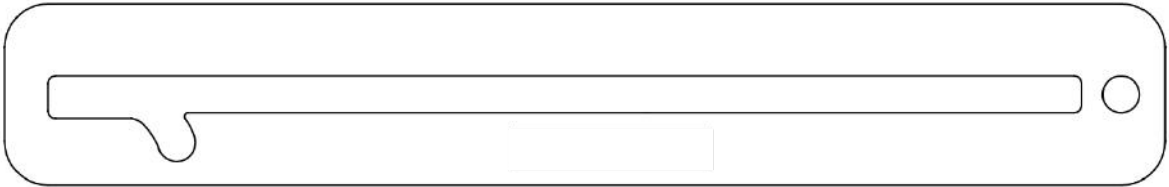

2x V2S.LP Lid prop

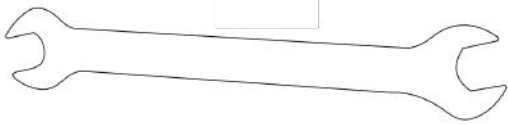

8mm / 10mm spanner



50x 100mm Cable tie



3mm allen key



4mm allen key

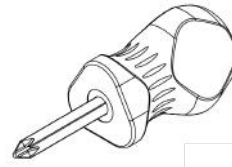

Screwdriver

01 - S16 introduction

Pre-install checklist

Allocate 2 hrs to the assembly of your S16. Do not remove components from their packaging before completing the step as its labelled on the packing. It can also help to read through the provided parts list and split the fasteners apart to make assembly smoother.

- Mobile phone/ tablet or laptop
- 240V power - waterproof socket. No extension leads.
- Secure fixing area - 1250 x 650 base dimensions
- Water Source - static supply from a clean water source
- Some steps will be easier with an extra pair of hands

2060 and 2020

2060 and 2020 in part names refers to cross sectional dimensions of the aluminium frame component.

2020

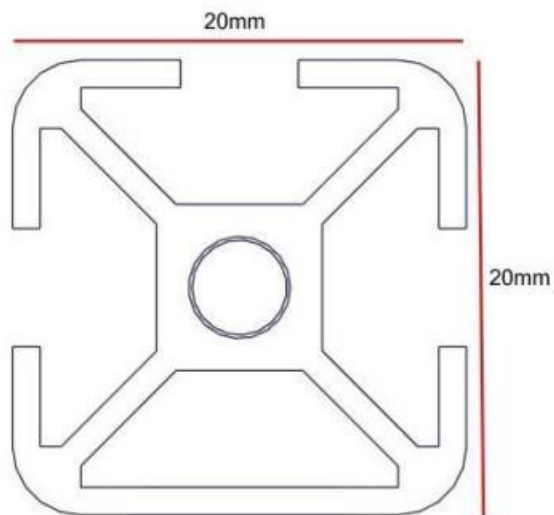

2060

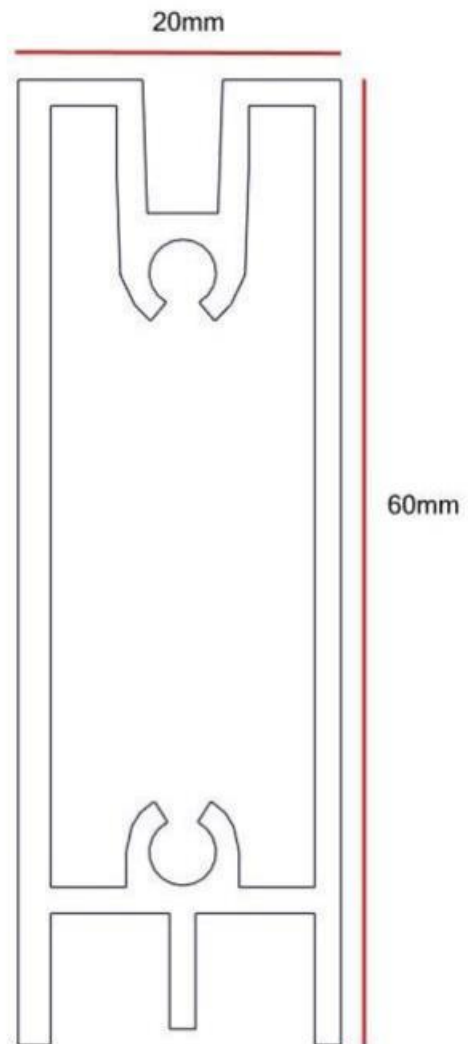

Installing channel nuts

Channel nuts allow components to be fixed to the slot in the side of the 2020 extrusion. The flush face of the channel nut always faces outwards.



Slotting alignment of the screw/ bolt head in channels

The bulk of the frame uses screws or allen head bolts in the channel of 2020 extrusion to secure in place. Take care in locating and threading screws to prevent cross threading and misalignment.



Positioning

Like all structures the longevity and safe operation of your S16 is only as good as the foundation it is fixed to.

Your S16 needs to be located on a flat, smooth surface measuring at least 1500mm x 600mm footprint with good access at the front.

Use the supplied stainless angle brackets as seen later in the guide and secure all 4 corners to the floor. For a concrete floor you could use raw plugs or we supply 30mm long stainless-steel screws for screwing into a wooden surface. It is also possible to secure the frame to a wall using the same brackets. Always ensure 4 fixing points for secure installation.

DO NOT...

- Position your S16 directly onto a soft surface such as soil or sand.
- Position your S16 indoors.
- Position on an uneven surface
- Use a contaminated water supply such as that from a lake or pond.
- Leave the door or lid open in bad weather

02 - Parts list

Please see separate parts sheet document / PDF. Use the document to confirm you have all the parts and familiarise yourself.

03 - Side assemblies

Parts list

- 2 x 2060.BY (45cm large aluminium)
- 2 x 2020.RS (rear side upright)
- 2 x 2020.FU (front upright)

Process

1. Place the large extrusion (2060.BY) the onto floor/table making sure the single channel is facing upwards.
2. Slide the front upright (2020.FU) with the closed face pointing away from 2060.BY (see diagram) over the two pre-installed screws or bolts.
3. Tighten through the two holes.
4. Slide the rear side upright (2020.RS), closed face out onto 2060.BY.
5. Tighten the screws/ bolts through the holes.

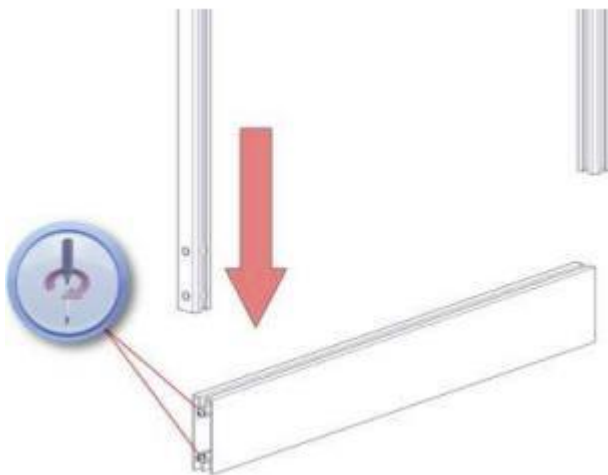

Follow steps again for the second side assembly.

04 - Rear frame assembly

Parts list

- 1 x 2020.RLB (Rear lower brace)
- 1 x 2020.RB (Rear brace)
- 2 x 2020.RM (Rear middle upright)
- 2 x M5X70.C (70mm bolt)
- 2 x 20mm.SP (20mm spacer)
- 1 x CMV (Centre Mesh Vent)
- 1 x S16.RCP (Rear centre panel)
- 6 x M5.CN (Channel nuts)
- 2 x ATP (Anti Twist Plate)
- 6 x M5X8.B button head bolts

Process

1. Place rear lower brace (2020.RLB) down flat on its side, then slide the M5x70 sockets through each of the large holes in the closed face.

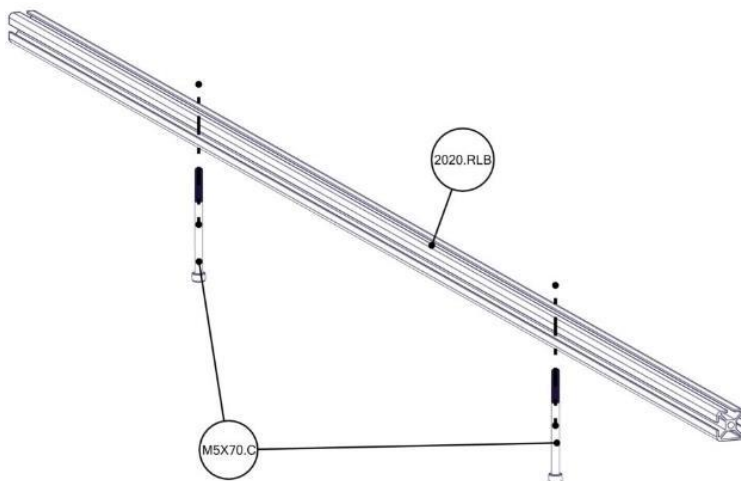

2. Slide the 20mm spacers (20MM.SP) over the exposed side of the M5x70 bolts.

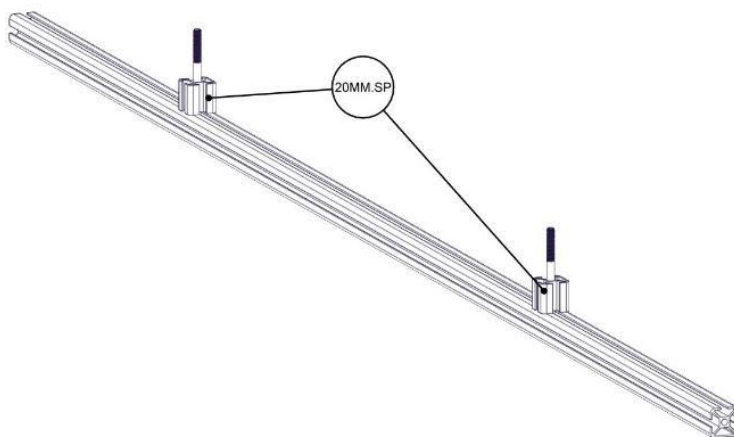

- Slot the centre mesh panel (S16.CMV) between the 2020 spacers, then slide one rear brace (2020.RB) over the exposed m5x70 bolts. Pay attention to the orientation of 2020.RB : the closed face is away from you.

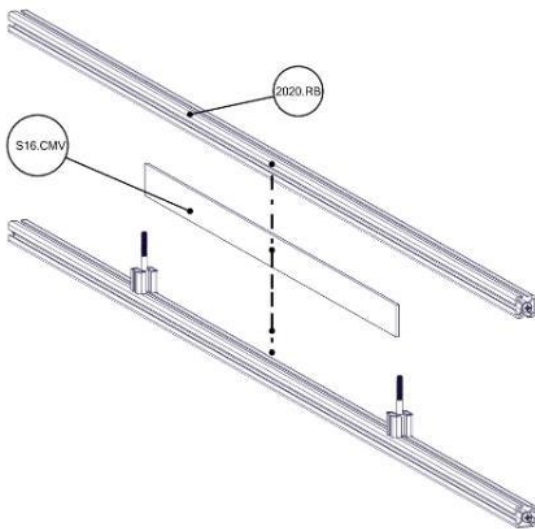

- Line each rear middle upright (2020.RM) up with the M5x70 bolts, matching the closed faces then bolt them in place using the 4mm allen key. **Laying the frame on a flat surface helps with alignment.**

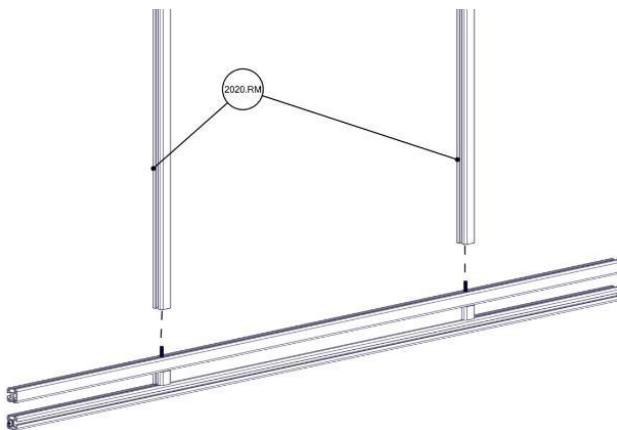

- Slide four M5 channel nuts (M5.CN) into open face of 2020.RB and one into each 2020.RM.
- Loosely fit M5x8 bolts into the channel nuts.
- Secure the anti-twist plates at the joints of the frame as shown below:

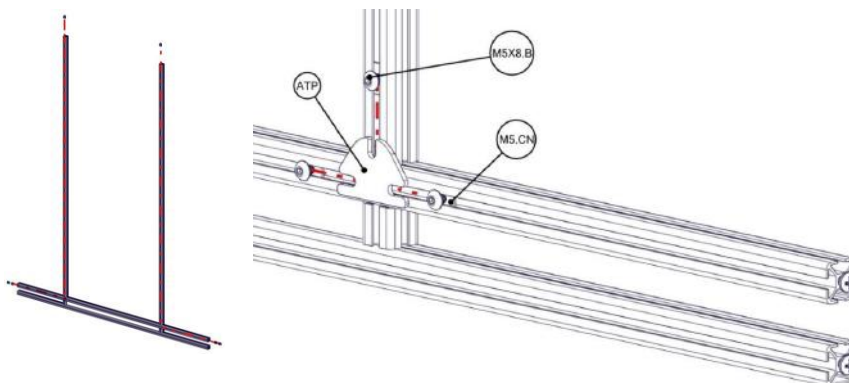

8. Insert the black rear centre panel (S16.RCP) into slots between the rear uprights (2020.RM).

Pay attention to the orientation of the holes of rear centre panel.

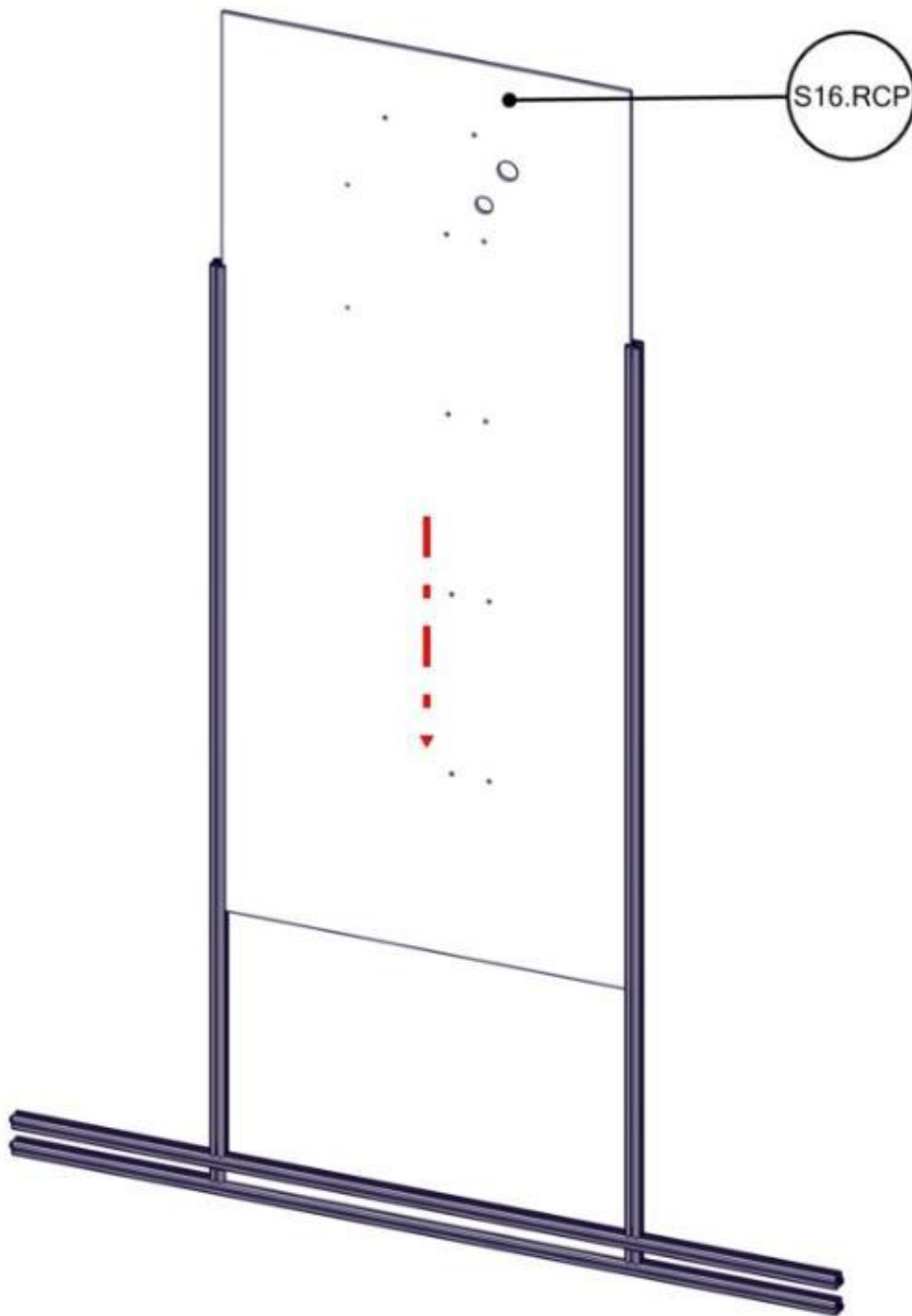

05 - Combine side and rear assemblies

Perform this step on a flat surface so that the greenhouse goes together square.

Parts

- 2 x S16.OMV (Outer mesh vents)
- 1 x rear assembly - step – 04
- 2 x side assemblies - step – 03
- 1 x 2060.DB (Door bottom)

Process

1. Slot the outer mesh vents (S16.OMV) into the open slots at the bottom of the rear assembly.



2. Slot the side assemblies from step 3 over the rear panel assembly.

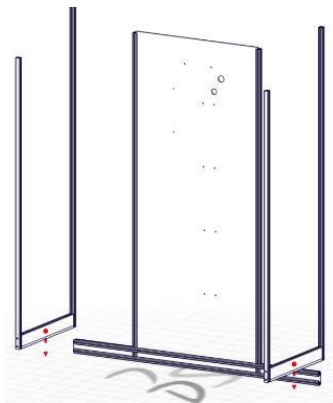

3. Place 2060.DB on the floor with the double channel facing upwards.
4. Slot the S16 frame over the open screws on either side and tighten.

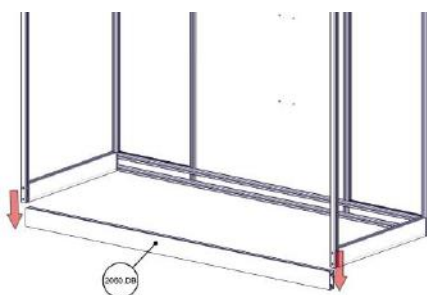

06 - Assemble shelf brackets

Parts list

- 3 x V2S.SSB.L (left shelf support)
- 3 x V2S.SSB.R (right shelf support)
- 24 x M5X8mm cap head bolts
- 24 x M5.CN (channel nuts)

Process

1. For each bracket you will need four M5 x 8 cap head bolts (M5x8.C) and four M5 channel nuts (M5.CN).
2. Push the bolts through the inner face of the L in the bracket and thread a channel nut to the back of it. Only thread partially as you will need to slide them into 2020 extrusion later.

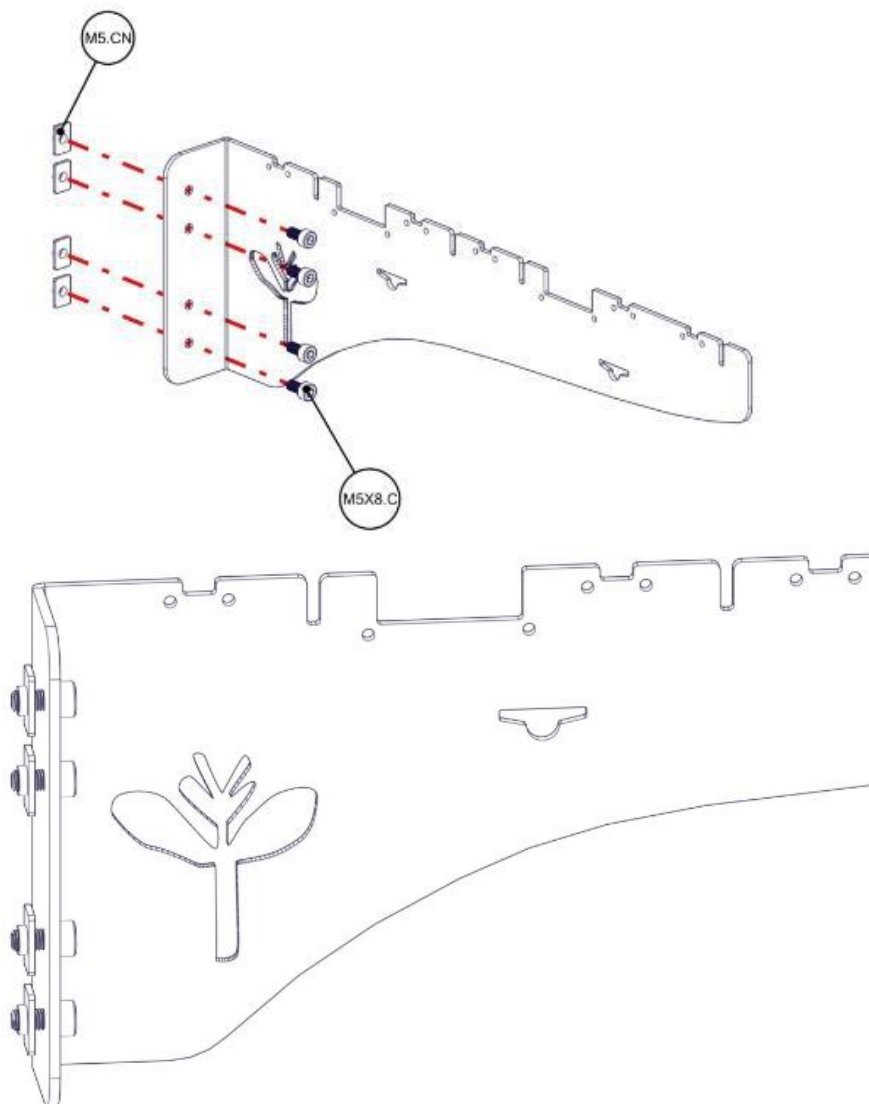

3. Repeat for the rest of the shelf brackets.

07 - Fit shelf brackets

Parts

- 6 x Shelf bracket assemblies - step 06
- Frame from step 05

Process

1. Slide the shelf brackets into the rear open face of the S16 frame, the flat side faced upwards.

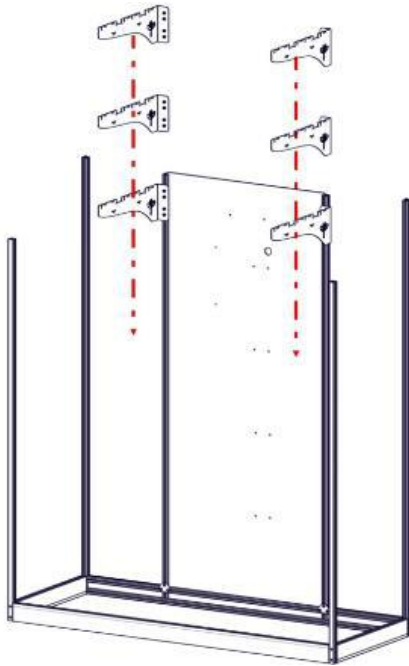

2. Set a distance of 250mm spacing between shelves and tighten the bolts with the 4mm allen key.

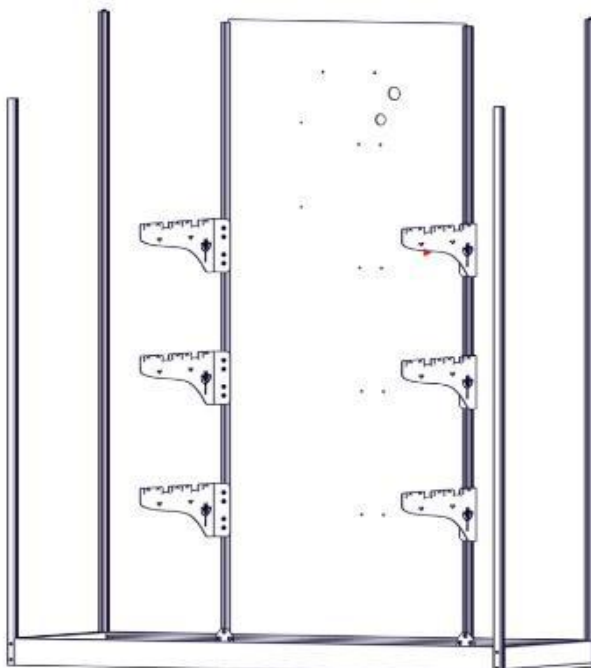

08 - Rear outer panels and top brace

Parts

- 2 x S16.ROP (Rear outer panel)
- 1 x 2020.RB (Rear brace)

Process

1. Slide the rear outer panels (S16.ROP) into the rear assembly making sure the end with rectangular cut outs are at the top rear of the frame.

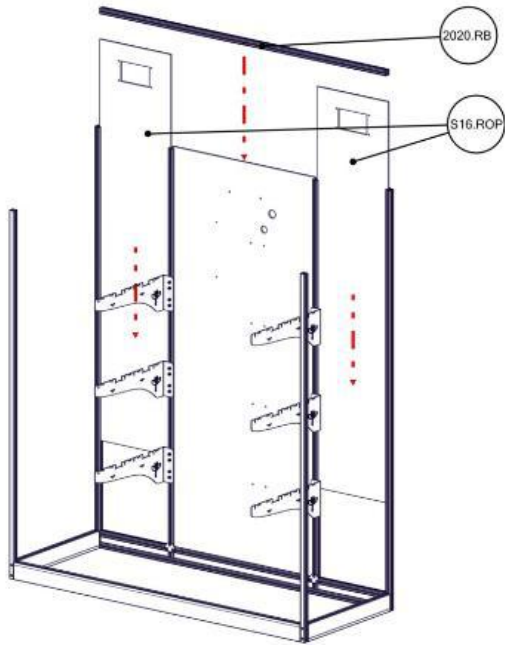

2. Slide the second rear brace (2020.RB) into the top of the rear panel closed face pointing backwards. Tighten through the holes in the rear uprights.

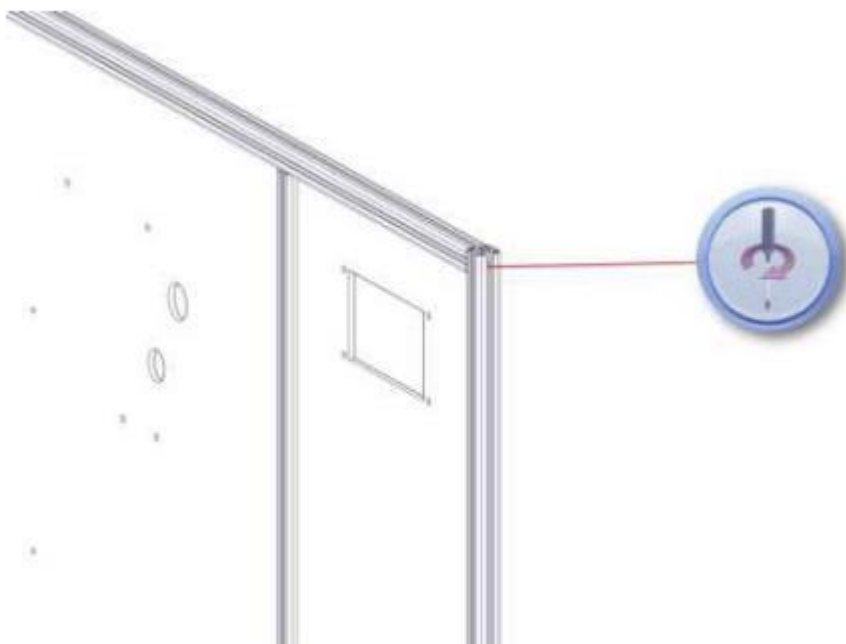

09 - Control box and power supply

Parts

- PSU.200W (power supply)
- Fasteners for this step can be found inside the control box packaging.

Mount the control unit

1. Open the tabs on either side of the control unit and push two M5 x 12 bolts (M5X12.B) through the holes. This is easier using the 3mm allen key to hold the bolts as you put them in.

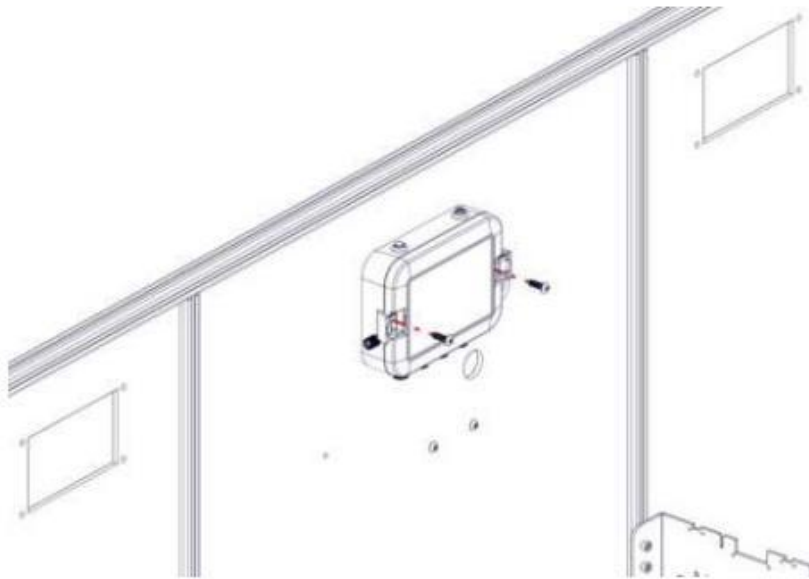

2. Place the control box onto upper left holes on the inside of the centre panel on your S16. Tighten with the M5 nyloc nut and M5 washer on the rear.

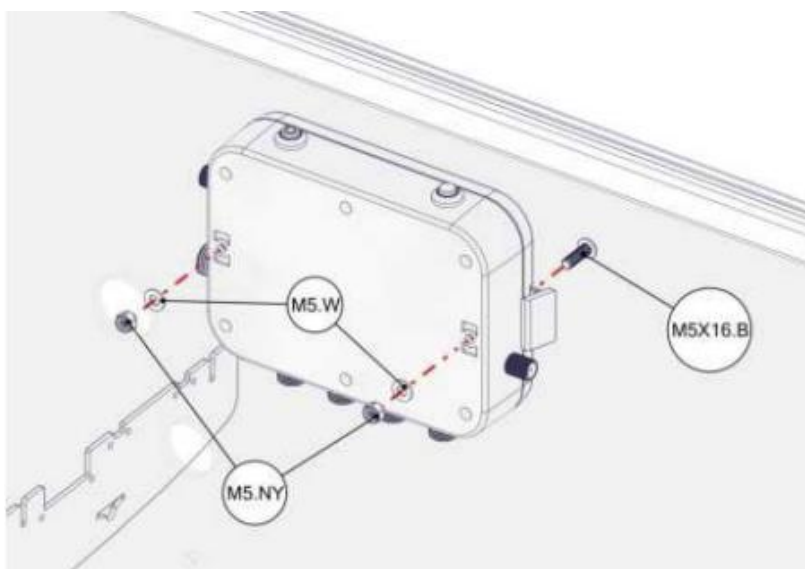

3. Plug the air temperature sensor into the top right port of the control unit labelled 'Temp'.

Light splitter cable

Plug in the light splitter cable to the right hand side port of the control unit labelled '4'.

Mount the power supply

The power supply sits on the outside rear face of the greenhouse, it is fully weather sealed so don't worry about the rain. Plug it into an inside plug or a IP67 weather sealed outdoor plug.

Don't use an extension lead.

Use the fixings supplied with the control unit.

1. From the outside of the greenhouse, push one M4x16 bolt (M4.16.CAP) through the lower hole marked in the attached diagram.
2. Fit one M4 washer (M4.PW) and one M4 wing nut (M4.WN) to the inside.

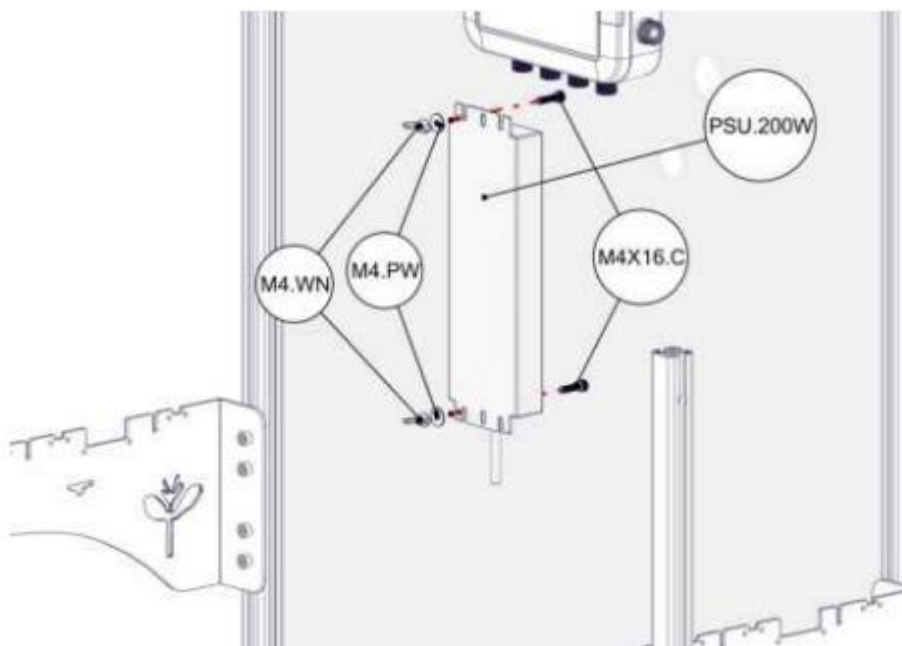

3. Slide the power supply down onto the bolt you have just fitted using the notches in the top and bottom of the casing, the end with the UK plug is facing down towards the ground.
4. Push another M4X16 bolt through the top hole and notch of the power supply then fit another M4 washer and M4 wing nut to the inside.
5. Tighten both wing nuts to securely fix the power supply in place.

10 - Extractor fans

Parts

- 2 x S16.EXK (Extractor kit)
- 8 x M5X70.C (70mm bolt)
- 8 x M5.N (M5 nut)
- 8 x 50MM.SO (50mm stand-off)

Process

You have two extractor kits in your S16, the one with two wires goes on the left when looking from the front and the one with a single wire goes on the right.

1. Push the black cover panel through the hole from the rear then push the extractor into place, the open end pointing downwards.

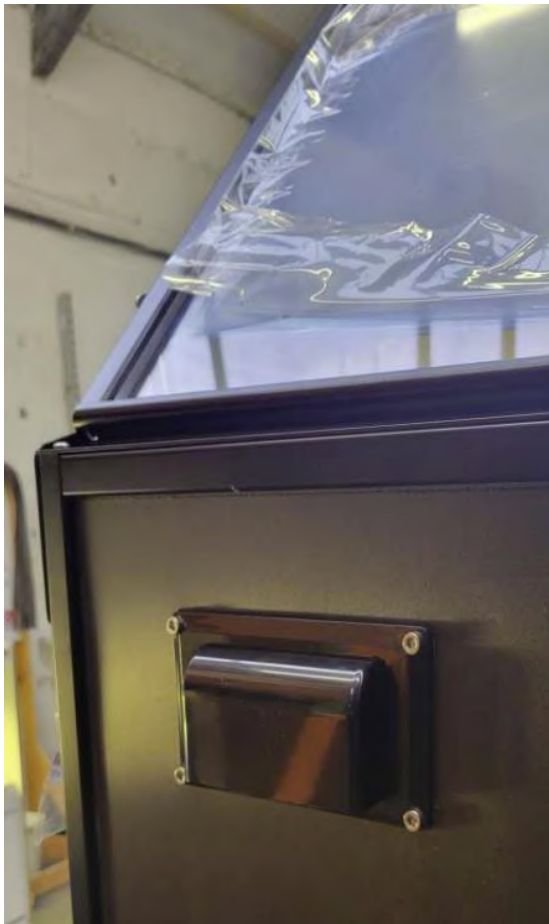

2. Push four M5X70.C bolts through from the rear.

3. Put 50MM.STAND.OFF over the open end of the bolt then place the cover plate on top. Make sure the wires on the cover plate point towards the control unit.



4. Tighten into place with M5.NUT.

Once both panels are in:

1. Connect the two together with the longer wire.
2. Connect the short wire to the top left hand side port of the control unit labelled 'fans'.

11 - Cable tie bases and irrigation downpipe

Parts

- 8 x M5X16.B (16mm bolt)
- 8 x M5.NY.N (nyloc nut)
- 1 x V2S.LDPE (downpipe)
- 1 x 14MM.EP (pipe elbow)
- 1 x 14MM.EB (end stop)
- 1 x HOSE.2.5M (braided garden hose)

Cable tie bases

Fit the cable tie bases to the interior of the S16 with M5x16 bolts (M5X16.B). The head of the bolt should sit flush in the cradle of the cable tie base. There are two sets of holes that run parallel down the back panel. Tighten them in place with M5 nyloc nuts (M5.NY) on the rear.

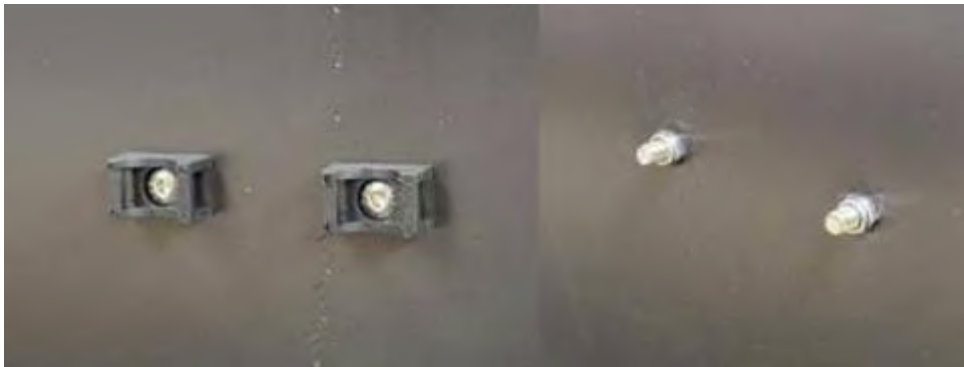

Irrigation downpipe

1. Use some hot water to soften one end of the rigid pipe. Push fit the 14mm elbow to this end. Soften the opposite end and push fit the 14mm end plug.
2. Thread the braided black hose through the hole in the rear panel
3. Soften the end of the braided hose and push fit the elbow from step 1 to the braided hose end.
4. Align the elbow into the panel hole. The downpipe should align with the right-hand side cable tie bases.
5. Fasten the downpipe to the right set of cable tie bases with the reusable cable ties.

12 - Shelf components

Parts

- 12 x LED.FLAT.BAR
- 6 x M5.WN (wing nut)
- 6 x M5X16.B (16mm bolt)
- 12 x M5.PW (penny washer)
- 2 x V2S.HCL (heater cable, long)
- 1 x V2S.HCS (heater cable, short)

Prepare LED light assemblies

1. Assemble the LED lights with the head of the bolt on the light tube side of the light components with a washer. The cable ends should be next to each other.

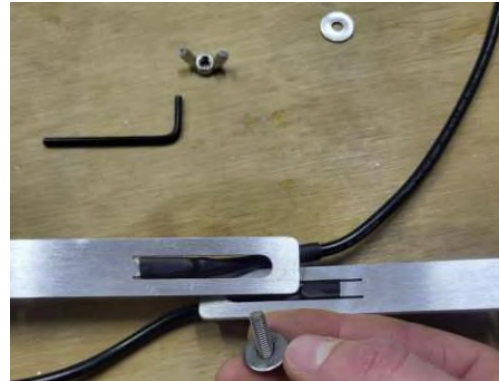

2. Install a washer (M5.PW) on the non light tube side followed by a m5 wing nut (M5.WN).

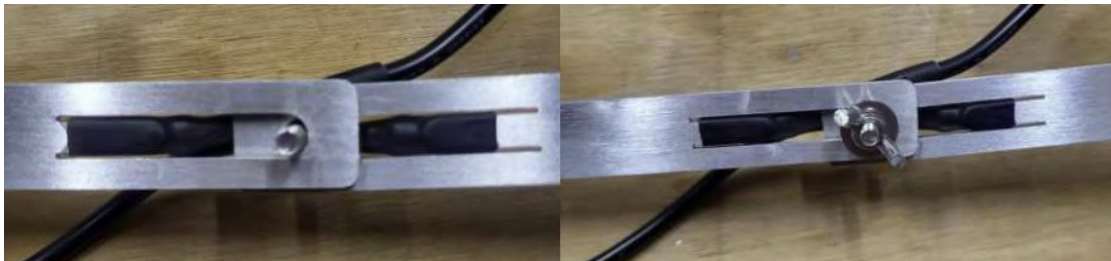

Install LED light assemblies

1. Slot the LED light assemblies into the slots of the shelf support brackets. 2 LED light assemblies per shelf.



Install heater cable

1. The two heater cables with the longer cable extension (V2S.HCL) are positioned on the lower shelves and the shorter (V2S.HCS) on the top shelf. Each support bracket has slots for fitting the heater cable. Position the heater cables roughly using these slots as per image below.

We'll secure them to the shelves later with cable ties.



13 - Mesh shelves

Parts

- 3 x S16.ZM (mesh shelf)
- CT.100X2.5 (10cm cable ties)

Process

1. Position the mesh shelves on the support brackets ensuring adequate spacing for the cable runs down the back of the greenhouse, and ensuring the shelves are flat against the surface of the bracket. You can use the notches in the shelf support brackets to align the mesh.

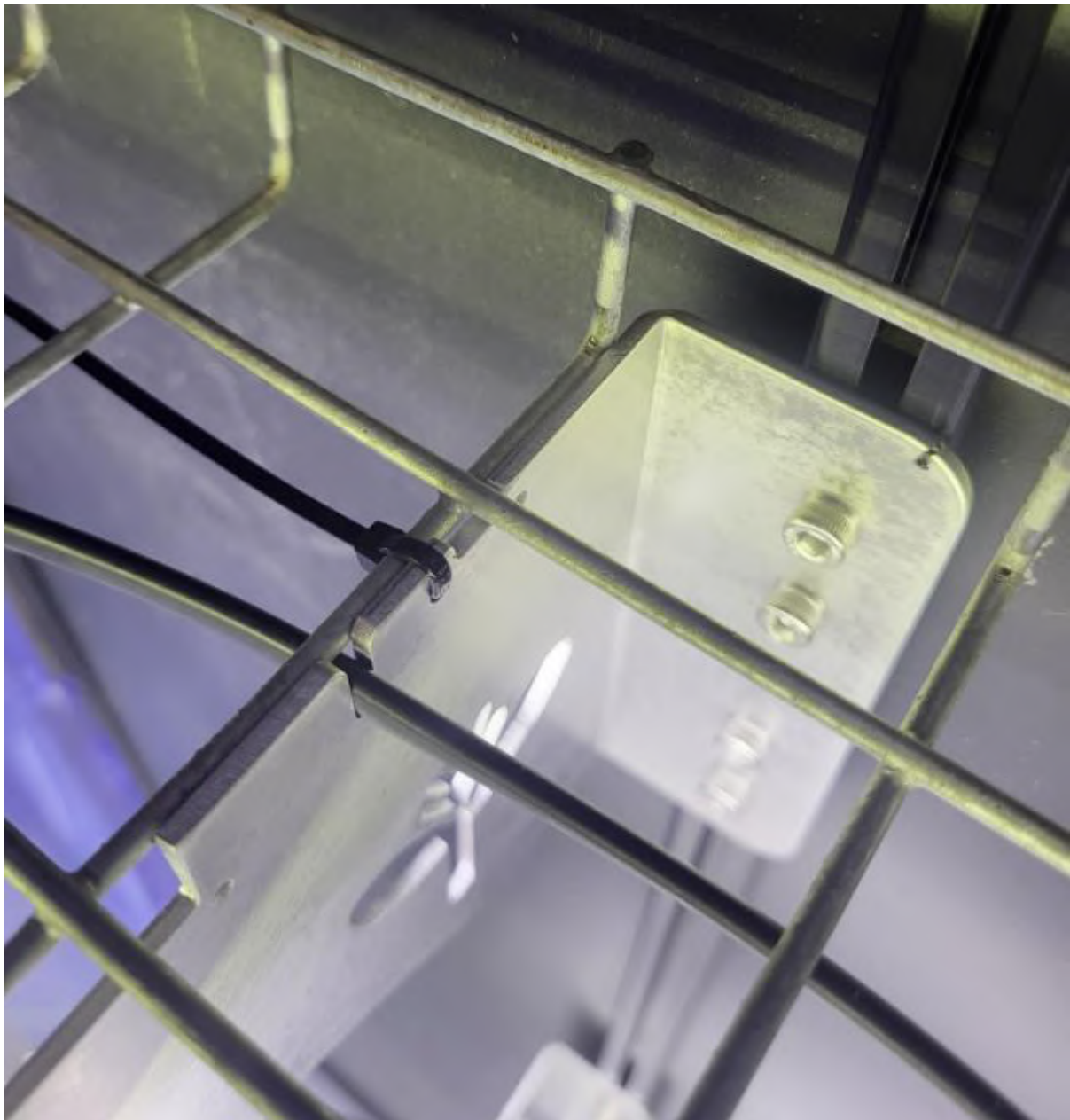

2. Use the 100mm cable ties to secure the mesh shelves to the shelf support brackets.

14 - Doors and top door bar

Parts

- S16 Frame
- 1 x 2060.TDB (top door bar)

Process

1. Position the door pairs in the double channel base extrusion as follows:

The front door has two handles on the **same** face and the Harvst logo on the top right. The front door goes in the front channel, slid to the **right**.

The rear panel has handles on **opposing** faces and brush weather strip.

2. Lower the top door bar (2060.TDB) over the doors, ensuring the double channel slots align with the top edge of the door pair.

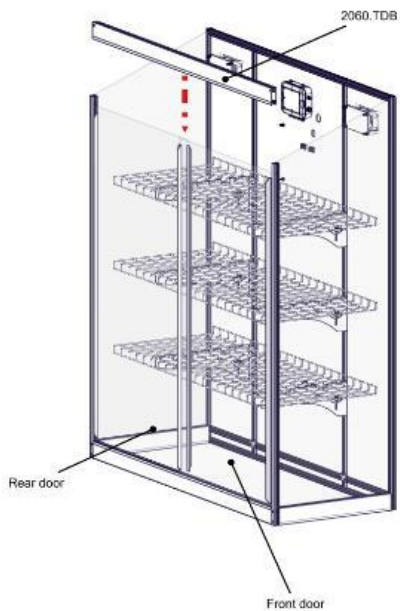

3. Tighten the 2 pre-positioned screws located at the ends of the top door bar through the front uprights.

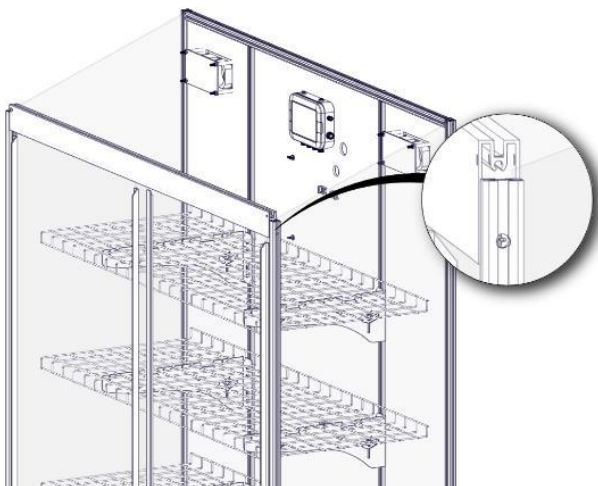

15 - Prepare top side assemblies

Parts

- 1 x SP.END.L
- 1 x SP.END.R
- 6 x M5X8.B (8mm button head bolts)
- 6 x M5.CN (channel nuts)
- 2 x M5x40.B (40mm button head bolts)
- 2 x M5.NY (nyloc nuts)

Process

Build up the top side assemblies as follows:

1. Slot two M5x8 bolts through the spare holes of the flat plate, in the direction shown in the drawing below.
2. Loosely fit a channel nut to each bolt on the inside.
3. Slide one M5x8 bolt through the outside face of the bent bracket.
4. Loosely fit a channel nut to the inside.
5. Repeat for other assembly.

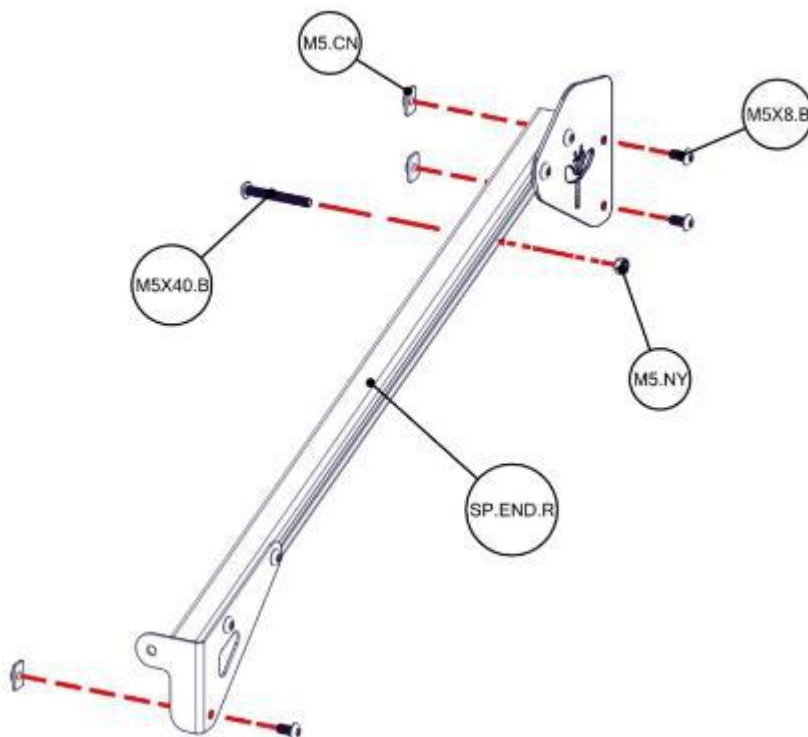

16 - Complete side frames

Parts

- Top side assemblies from step (previous)
- 2 x V2S.SA3 (clear side panel)
- 6.5m x V2S.GST (sealing trim)
- 2 x M5.NY (M5 nyloc nut)
- 2 x M5X30.B (M5 x 30mm button head)
- 2 x M5.PW (M5 penny washer)

** Warning!

Glazing edges are sharp. Please wear protective gloves when handling.

Process

1. Remove the film from the outside edges of both faces of the side panels (V2.SA3). Slide the side panels into the sides of the greenhouse as per diagram below.

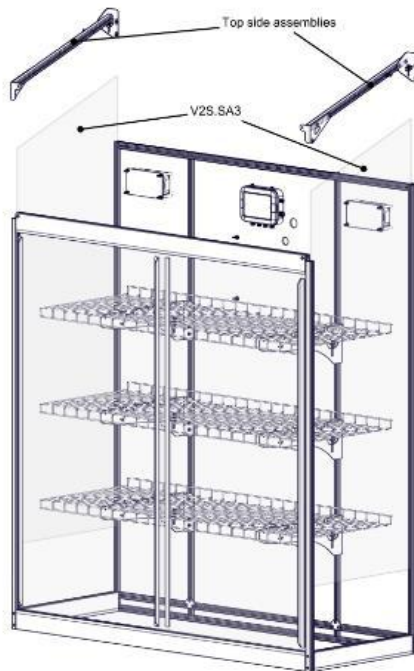

2. Fit the glazing seal (V2S.GST) to the upright edges. The narrow short edge of the trim, outlined in green, slots between the glazing surface and the outer edge of the frame channel.

Start at one end and work the seal edge in ensuring the seal trim isn't bunched up. Use sharp scissors to cut the length required.



Next, we'll drop in the top side assemblies.

1. Slide down the top side assembly until it is fully seated and the rear upright is flush with edge of the side assembly as per diagram below.

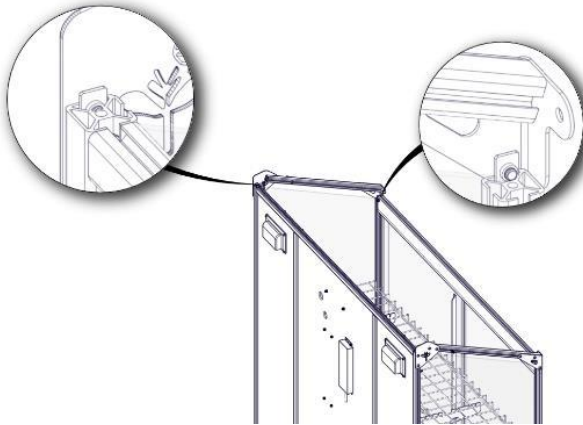

2. Repeat for left hand side.
3. Tighten the M5X8.B in the channels for both sides.

Now, for some more glazing strip.

1. Install glazing seal on top edge of the side assembly.
2. Secure the front corner bracket of the side assemblies to the top door bar using the M5X30.B bolts, penny washer and M5 nyloc.

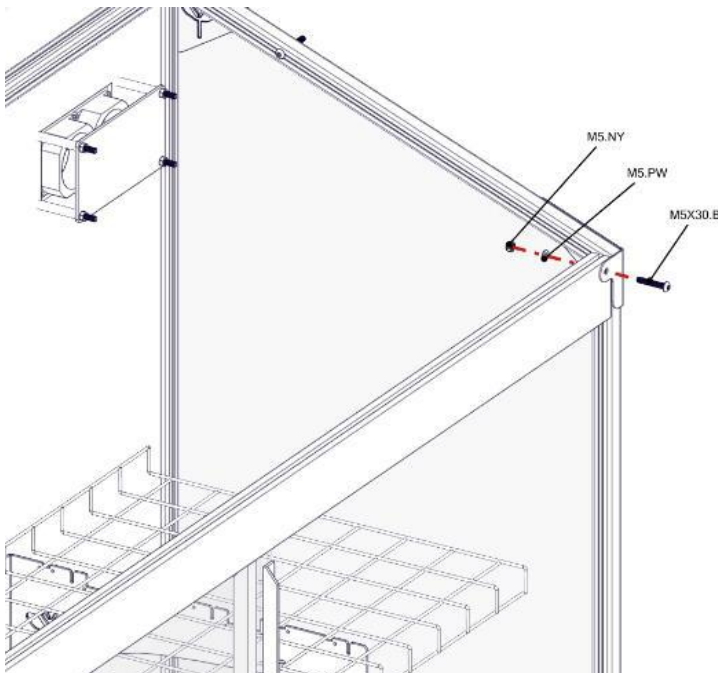

17 – Lid

Parts

- 1 x S16.BL (built lid)
- 1 x S16.LRP (lid ridge plate)
- 2 x M5X30.B (30mm button head bolts)
- 2 x 4.8X10.PAN (pan head screws)

Process

1. Slot the ridge plate (S16.LRP) into the slot in the lid.
2. Place the lid over the S16 frame, the hinging side goes at the top rear.
3. Fix down into the outside rear uprights through the holes using screws (4.8X10.PAN).
4. Fix down to centre uprights through the holes using bolts (M5x30.B).

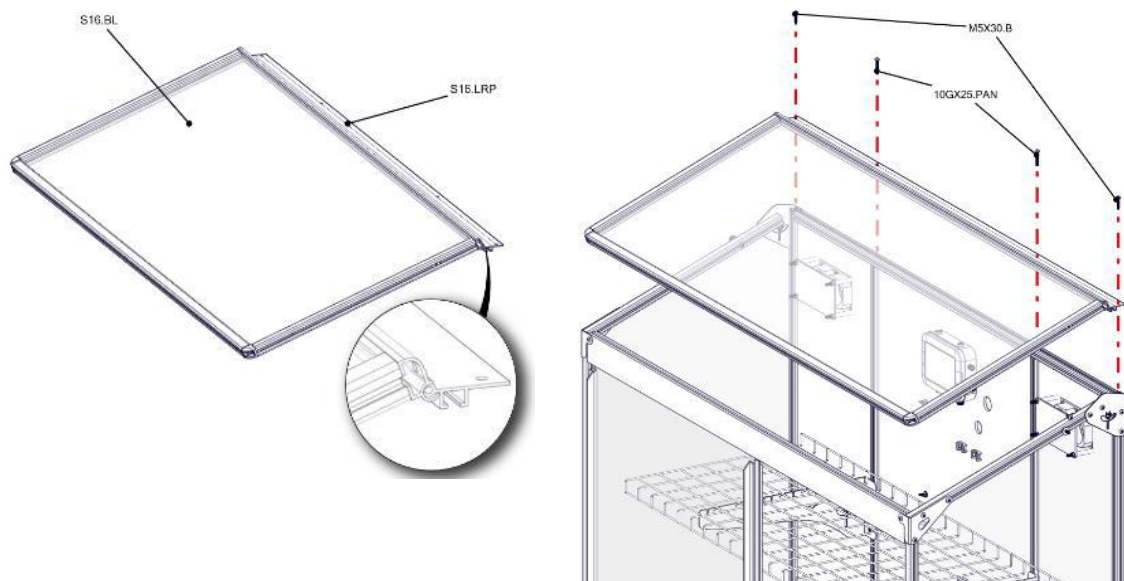

18 - Lid prop

Parts

- 2 x lid props 2 x M5X16.B (16mm button head bolts)
- 2 x M5.RW (plastic spacer / washer)
- 2 x M5.PW (penny washer)
- 2 x M5.PHN (plastic handle nut)

Process

Each side is built up using the same steps.

1. Paying attention to the orientation of the lid prop (see below diagram), locate the M5x16 bolt through the hole at the top of the lid prop then place a plastic spacer onto the threaded end of the bolt.
2. Partially thread this assembly into the channel nut located in the lid assembly.
3. Position the bolt centre 100mm (4") from the rear of the lid as shown below.
4. Repeat with the other side.

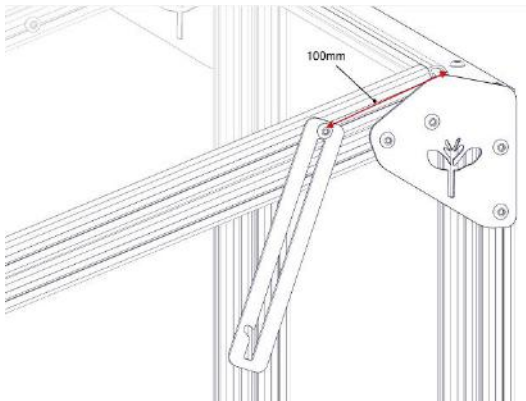

5. Slide the lid prop slot over the M5x40 in the top side assembly.
6. Place a penny washer over the end of the M5X40 end followed by the plastic handle nut:

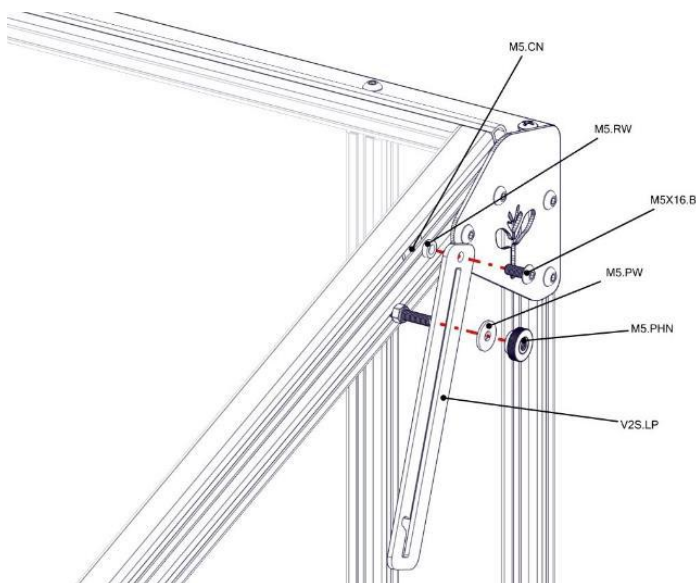

When the lid is not in use, tighten the plastic nut to prevent the lid from opening in bad weather.

19 - Fit securing brackets

Parts

- 4 x SAB.3030 (angle brackets)
- 4 x M5X8.B (8mm button head bolts)
- 4 x M5.CN (channel nuts)
- 4 x 10GX25.PAN (screws)

Process

Ensure your S16 is located on a flat rigid surface with good access to power and sunlight.

1. Prepare your securing brackets as in the diagram.

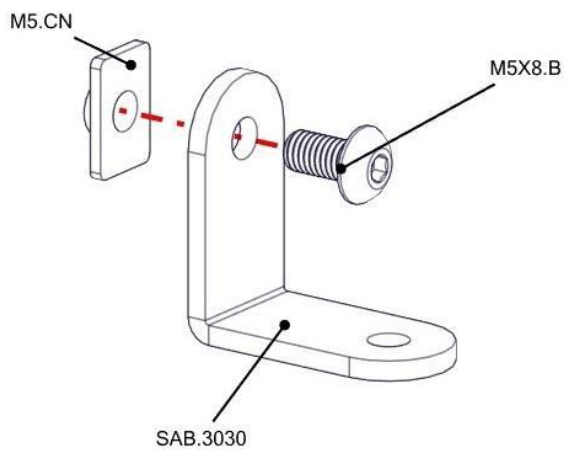

2. Slot the securing bracket assemblies into the channel of the outer uprights on all 4 corners
3. Ensure the bottom face is flush with the floor and secure in place using the 3mm allen key

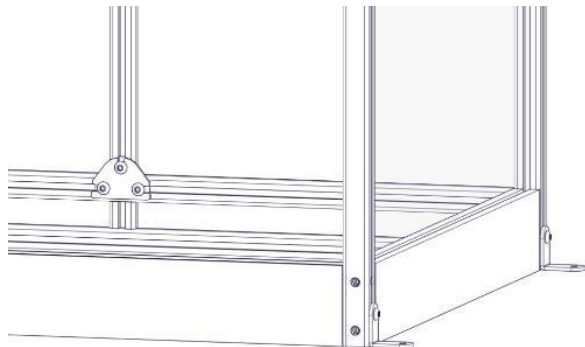
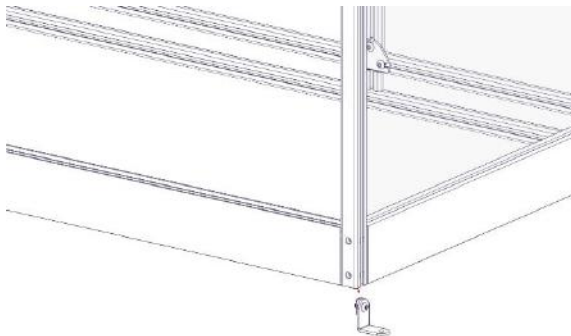

The four brackets can also be used on the rear of the greenhouse to secure it to a fence or wall.

Congratulations! Your greenhouse is now complete!